



This manual contains important warnings and information.
READ AND KEEP FOR REFERENCE.

INSTRUCTIONS

First choice when quality counts.™

Preset

PM5™ Electronic Metered Dispense Valves

1000 psi (7 MPa, 69 bar) Maximum Working Pressure

5 gpm (18.9 lpm) Maximum Flow Rate

Factory-Set to Measure in Quarts

Model 238501	75° bend 3/8-in. rigid tube
Model 238502	3/8-in. coupled flexible hose
Model 238505	90° offset

Factory-Set to Measure in Liters

Model 238503	75° bend 3/8-in. rigid tube
Model 238504	3/8-in. coupled flexible hose
Model 238506	90° offset

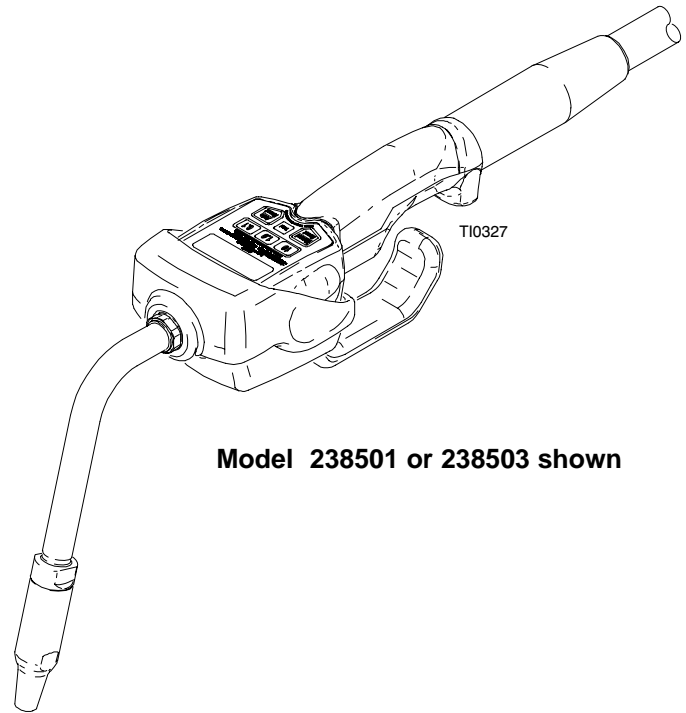

Model 238501 or 238503 shown

⚠ CAUTION

- This dispense valve is designed to dispense petroleum-based lubricants and antifreeze only. **Do not dispense windshield washer solvent with this dispense valve.**
- This dispense valve is designed for indoor use only.
- This dispense valve is not designed for in-line installation. Do not install with a shut-off valve on the outlet side of the meter. Such installation could result in damage to the meter housing cover.

Registered Design No. 1025804



97D.122550
EExia II A/B T3



APPROVED

INTRINSICALLY SAFE FOR
HAZARDOUS LOCATIONS
CLASS 1, DIV. 1, GROUP D



GRACO INC. P.O. BOX 1441 MINNEAPOLIS, MN 55440-1441

©COPYRIGHT 1998, GRACO INC.

Graco Inc. is registered to I.S. EN ISO 9001

Table of Contents

Warnings	2
Installation	4
Setup	7
Operation	11
Troubleshooting	13
Service	16
Parts List	18
Parts Drawing	19
Technical Data	20
Dimensional Drawing	21
Graco Standard Warranty	24
Graco Phone Number	24

Symbols

Warning Symbol



This symbol alerts you to the possibility of serious injury or death if you do not follow the instructions.

Caution Symbol



This symbol alerts you to the possibility of damage to or destruction of equipment if you do not follow the instructions.

! WARNING



INSTRUCTIONS

EQUIPMENT MISUSE HAZARD

Equipment misuse can cause the equipment to rupture or malfunction and result in serious injury.

- This equipment is for professional use only.
- Read all instruction manuals, tags, and labels before you operate this equipment.
- Use the equipment only for its intended purpose. If you are not sure, call your Graco distributor for assistance.
- Do not alter or modify this equipment. Use only genuine Graco parts and accessories.
- Do not leave this dispense valve unattended while it is dispensing.
- Check equipment daily. Repair or replace worn or damaged parts immediately.
- Do not exceed the maximum working pressure of the lowest rated system component. See the **Technical Data** on page 20 for the maximum working pressure of this component.
- Use fluids and solvents that are compatible with the equipment wetted parts. See the **Technical Data** section of all equipment manuals. Read the fluid and solvent manufacturer's warnings.
- Route hoses away from traffic areas, sharp edges, moving parts, and hot surfaces. Do not expose Graco hoses to temperatures above 180° F (82° C) or below -40° F (-40° C).
- Comply with all applicable local, state, and national fire, electrical, and safety regulations.
- Do not point the dispense valve at anyone or at any part of the body.
- Do not put your hand or fingers over the end of the dispense valve.
- Do not stop or deflect leaks with your hand, body, glove, or rag.
- Use only extensions and nozzles that are designed for use with this dispense valve.
- Follow the **Pressure Relief Procedure** on page 5 before you clean, check, or service this equipment.
- Tighten all fluid connections before you operate this equipment.
- Check the hoses, tubes, and couplings daily. Replace worn or damaged parts immediately. Do not repair high pressure couplings; you must replace the entire hose.

WARNING



FIRE AND EXPLOSION HAZARD

Improper grounding, poor ventilation, open flames, or sparks can cause a hazardous condition and result in a fire or explosion and serious injury.

- Be sure the entire fluid system is properly grounded. Refer to your pump instruction manual for complete details. See **Grounding** on page 6.
- If there is any static sparking or you feel an electric shock while using this equipment, **stop dispensing immediately**. Do not use the equipment until you identify and correct the problem.
- Provide fresh air ventilation to avoid the buildup of flammable fumes from solvents or the fluid being dispensed.
- Keep the dispensing area free of debris, including solvent, rags, and spilled gasoline.
- Do not smoke while flammable fluids or fumes are in the dispensing area.

Installation

Typical Installations

Fig. 1 shows a typical hose reel installation. These dispense valves can also be installed on a console, as shown in Fig. 2.

⚠ CAUTION
Do not use this dispense valve on non-Graco consoles. Such use could result in the trigger becoming inadvertently pressed while the dispense valve is stowed.

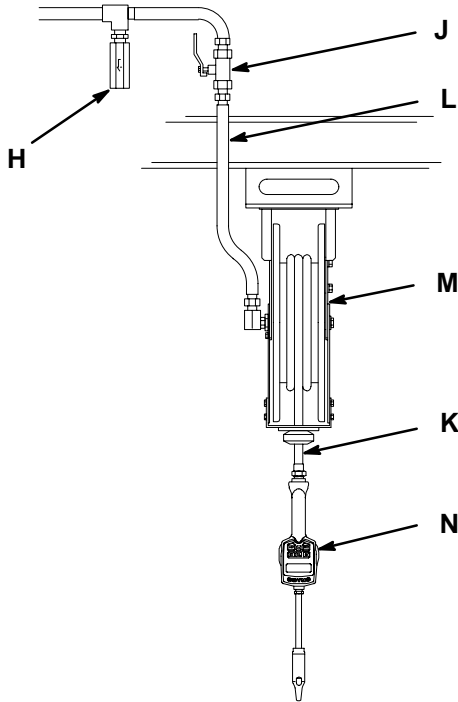

Fig. 1 06174B

KEY	DESCRIPTION
H	Thermal relief kit (required) Part No. 235998 <i>Install downstream from pump.</i>
J	Fluid shut-off valve
K	Hose
L	Hose reel fluid inlet hose
M	Hose reel
N	PM5 electronic metered dispense valve

The typical installation shown in Fig. 1 is only a guide. The components shown are typical; however, it is not a complete system design. Contact your Graco distributor for assistance in designing a system to suit your particular needs.

⚠ CAUTION
This dispense valve is not designed for in-line installation. Do not install with a shut-off valve on the outlet side of the meter. Such installation could result in damage to the meter housing cover.

Mounting Bracket

Mounting bracket 196471 is available for resting a PM5 dispense valve on a console. See Fig. 2.

⚠ CAUTION
Do not obstruct the trigger of this dispense valve, and do not set the unit down resting on its trigger, or it might not stop dispensing.

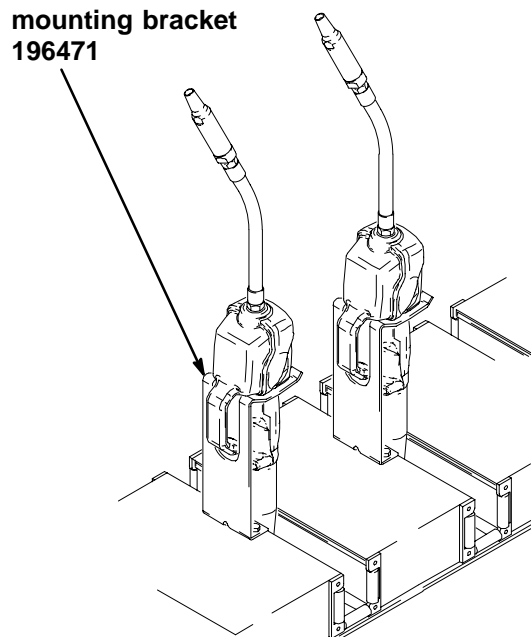

Fig. 2 T10334

Installation

WARNING

PRESSURIZED EQUIPMENT HAZARD

The equipment stays pressurized until pressure is manually relieved. To reduce the risk of serious injury from pressurized fluid, accidental spray from the dispense valve, or splashing fluid, follow the **Pressure Relief Procedure** when you

- Are instructed to relieve pressure
- Check, clean, or service any system equipment
- Install or clean fluid nozzles or filter

Pressure Relief Procedure

1. Turn off the power supply to the pump.
2. Trigger the dispense valve into a waste container to relieve pressure.
3. Open any bleed-type master air valves and fluid drain valves in the system.
4. Leave the drain valve open until you are ready to pressurize the system.

WARNING



FIRE AND EXPLOSION HAZARD

The movement of fluids through the dispensing system generates static electricity. The static electricity can cause volatile fumes to ignite, resulting in explosion and fire. The dispensing system must be grounded. See **Grounding** on page 6.

Pre-Installation Procedure

1. **Relieve the pressure.**

WARNING

To reduce the risk of serious injury whenever you are instructed to relieve pressure, always follow the **Pressure Relief Procedure** above.

2. Close the shut-off valve (item J in Fig. 1).
3. Ground the hose and reel or console. See **Grounding** on page 6. Leave a minimum two engaged threads bare when using Teflon® tape. The bare threads ensure a ground is maintained.

Installation Procedure

CAUTION

If this is a new installation, or if the fluid in the lines is contaminated, flush the lines before you install the metered valve. Contaminated lines could cause the valve to leak.

1. If this is an existing installation, go to step 7.

*Steps 2 through 6 are the **Flushing Procedure**.*

2. Close the fluid shut-off valve (J) at each dispense position.
3. Make sure the main fluid outlet valve at the pump is closed, the air pressure to the pump motor is adjusted, and the air valve is open. Slowly open the main fluid valve.
4. Place the hose end (with no dispense valve connected) into a container for waste oil. Secure the hose in the container so it will not come out during flushing. If you have multiple dispense positions, first flush the dispense position farthest from the pump, and work your way toward the pump.
5. Slowly open the shut-off valve (J) at the dispense position. Flush out a sufficient amount of oil to ensure that the entire system is clean, and close the valve.
6. Repeat step 5 at all other dispense positions.
7. **Relieve the pressure.**

WARNING

To reduce the risk of serious injury, whenever you are instructed to relieve pressure, always follow the **Pressure Relief Procedure** at left.

8. Slide the swivel cover (4) of the PM5 onto the hose, small end first. See Fig. 3.
9. Apply thread sealant to the male threads of the hose fitting, thread the hose fitting into the swivel (3) of the PM5, and tighten it firmly. See Fig. 3.

NOTE: Make sure you let the sealant cure to the manufacturer's recommendations before you let fluid into the system.

Installation

- Thread the sealing nut (5c, 6c, or 7c) onto the extension (5a) or street elbow (6d or 7d), thread the extension or elbow in at least three full turns, position it for proper alignment, and tighten the sealing nut. The Teflon® seal on the sealing nut must face the valve housing. See Fig. 4.

NOTE: The flexible extension (6a) can also be threaded directly into the meter outlet without the street elbow or sealing nut. See the note in the **Parts Drawing** on page 19.

- Thread the new nozzle (5b, 6b, or 7b) onto the extension, and, with an open-end adjustable wrench, tighten it firmly. See Fig. 4.

NOTE: **Only** tighten the nozzle with the wrench on the flats of the nozzle bushing. **Do not disassemble the bushing from the nozzle.** Disassembly will affect the performance of the nozzle.

⚠ WARNING

Do not use Graco's old nozzle (Part No. 203655) or any other manual shut-off nozzle on the PM5 extension. You must use the new automatic nozzle that is provided with the PM5, or the meter could be damaged. Do not use any sealant material.

- Open all dispense position shut-off valves, and start the pump to pressurize the system. See the **Operation** section for proper operation of meter.
- To ensure dispensing accuracy, purge all air from the fluid lines and dispense valve before you use it. Set the system flow to the desired flow rate, which is typically 1.5 gpm. Do not exceed a 5-gpm flow rate.

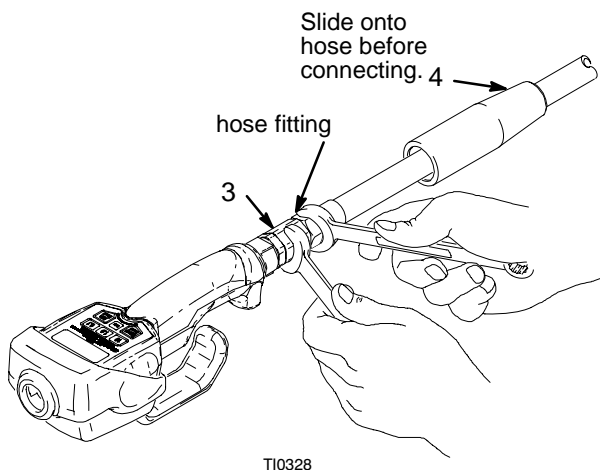

Fig. 3

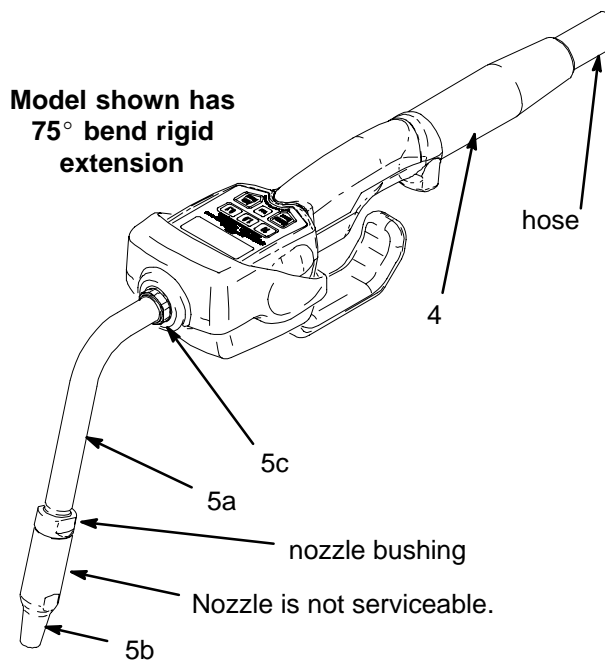

Fig. 4

T10327

Grounding

Proper grounding is an essential part of maintaining a safe system.

To reduce the risk of static sparking, ground all system components according to local and national electrical codes. Refer to the user manuals for the pump and other system components, and ground the following:

- *Pump:* Follow the manufacturer's recommendations.
- *Air and Fluid hoses:* Use only grounded hoses.
- *Air compressor:* Follow the manufacturer's recommendations.
- *Fluid supply container:* Follow the local code.

To maintain grounding continuity when flushing or relieving pressure, always hold a metal part of the valve firmly to the side of a grounded metal pail, then trigger the valve.

Setup

Terms

The following terms are shown on the display and/or used often in this instruction manual.

- **R-TOTAL:** resettable total
Displayed to show the cumulative amount that the dispense valve has dispensed in all modes. It can be reset to zero.
- **TOTAL:** non-resettable total
Displayed to show the cumulative amount that the dispense valve has dispensed in all modes for the history of the unit. It cannot be reset.
- **MANUAL mode**
Dispense mode in which the display counts up from zero to show the dispensed amount. In this mode, you may lock the trigger, but you must manually unlock it when the desired amount is dispensed. Memory setting also unlocks the trigger.
- **AUTO mode**
Dispense mode in which a preset, user-entered amount is dispensed. When the preset amount is dispensed, a beep sounds, the trigger unlocks to stop the unit from dispensing, and the amount dispensed is displayed. At this point, you may dispense more by pulling back the trigger, and the display resumes counting up in Manual mode.
- **Asleep / Awake**
Asleep is a battery-saving mode in which the display goes blank after 45 seconds of inactivity during normal operation and 2 minutes when in the options menu. The display comes *awake* from sleep mode when you press the Manual/Reset or Auto/Reset button, but not when you squeeze the trigger to dispense fluid. The unit **does** keep track of the amount dispensed while the display is asleep.

NOTE: If the unit falls asleep after any dispense cycle, and you wake it up by pressing the Auto/Reset button, the previously dispensed amount is cleared, and the Auto mode dispense amount stored in memory is displayed. You will be at the beginning of an Auto mode dispense cycle.

Keypad Buttons

The buttons on the keypad and their functions are as follows (see the figure below):

- **10, 1.0, and 0.1**
Used in Auto mode and during setup to enter dispense amounts.
- **MANUAL / RESET and AUTO / RESET**
Used individually to select Manual mode and Auto mode. Used together (pressed simultaneously) to access the setup menus.
For both of these buttons, the first push selects the mode, and the second push resets the display to zero.
- **TOTAL**
Used in any mode to see the resettable total and the non-resettable total.

NOTE: All buttons are disabled while fluid is being dispensed.

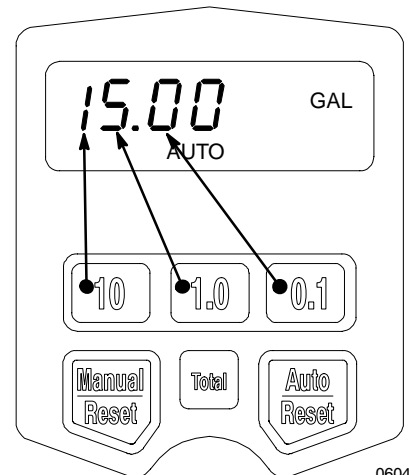

06044A

Setup

Selecting Dispensing Options

This is the procedure for setting or changing the resettable total, units of measurement, calibration factor, auto preset amount, and shut-off default amount:

1. If the display is asleep, wake it up by pressing the Manual/Reset or Auto/Reset button.
2. To enter the dispensing options menus from any mode, **press and hold the Manual/Reset and Auto/Reset buttons simultaneously** for four seconds.

The first menu is the Resettable Total menu, which is described in the first subsection below. You can advance through the menus by pressing the Auto/Reset button. You will know which menu you are in, because a menu indicator will be blinking in the display. The value that is displayed when you leave each menu and advance to the next is the value that gets stored.

Resettable Total

In this menu, you can reset the resettable total to zero or leave it unchanged. The resettable total accumulates until the next time it is manually reset.

1. If you have not already entered the dispensing options menus, do steps 1 and 2 in **Selecting Dispensing Options** above.
2. With **R-TOTAL** blinking and the current resettable total displayed, as shown below, do **ONE** of the following two options:

- Press the Manual/Reset button.

The resettable total is set to zero, and **0 GAL** or **0 LITERS** is displayed.

You can press the Manual/Reset button again to toggle between zero and the previously displayed resettable total. To lock in the displayed value and advance to the Units of Measurement menu, press the Auto/Reset button.

OR

- Press the Auto/Reset button.

The currently displayed value is stored, and the display advances to the Units of Measurement menu.

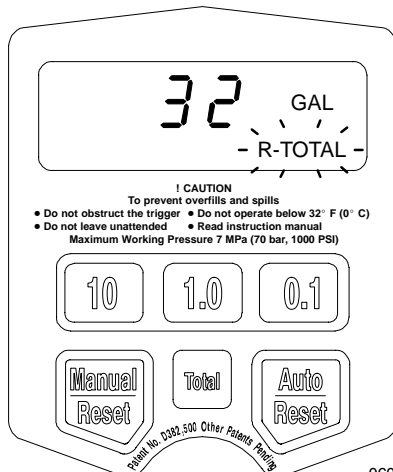

06044A

Units of Measurement

In this menu, you can set the units of measurement to quarts, gallons, pints, or liters.

1. If you have not already entered the dispensing options menus, do steps 1 and 2 in **Selecting Dispensing Options** above.
2. Press the Auto/Reset button repeatedly until **QTS**, **GAL**, **LITERS**, or **PTS** blinks to indicate that you are in the Units-of Measurement menu.
3. With **QTS**, **GAL**, **LITERS**, or **PTS** blinking, as shown below, do **ONE** of the following two options:

- Press the Manual/Reset button.

Each time you press the Manual/Reset button, the display scrolls to the next unit of measurement. To lock in the new unit of measurement and advance to the Calibration Factor menu, press the Auto/Reset button.

OR

- Press the Auto/Reset button.

The displayed unit of measurement is retained, and the display advances to the Calibration Factor menu.

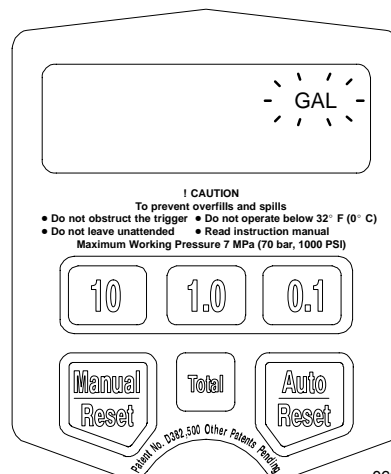

06044A

Setup

Calibration Factor

In this menu, you can recalibrate the meter for different fluids.

1. If you have not already entered the dispensing options menus, do steps 1 and 2 in **Selecting Dispensing Options** on page 8.
2. Press the Auto/Reset button repeatedly until **CAL** blinks and the current calibration factor is displayed to indicate that you are in the Calibration menu.
3. With **CAL** blinking, you can press the Auto/Reset button and choose **not** to change the calibration factor, which advances to the Auto Preset Amount menu.

OR

You can recalibrate the meter as follows:

- 3a. If the unit of measurement is liters, dispense exactly one liter of fluid into a calibrated 1-liter container. If the unit of measurement is gallons, pints, or quarts, dispense exactly one quart of fluid into a calibrated 1-quart container. For proper calibration, you must dispense the exact amount, according to the markings on the container.

After dispensing, the displayed number is the new calibration factor. The new calibration factor must be within 20 percent of the factory default value [in the range of 294 gal. (310 liters) to 442 gal. (467 liters)], or it will not be accepted.

The following table lists approximate calibration factors for different fluids. Your calibration number may vary slightly due to temperature or flow rate.

Fluid	Calibration Number	
	Quarts	Liters
oil (10W-30)	368	389
gear lube	368	389
automatic transmission fluid	368	389
antifreeze	347	367

Calibration factors at 70° F (21° C) at 2.0 gpm (7.6 lpm).

- 3b. Press the Auto/Reset button to store the new calibration factor and advance to the Auto Preset Amount menu.

Auto Preset Amount

In this menu, you can specify an amount to be displayed when you enter the Auto dispense mode. Typically, you would enter the amount you most frequently dispense.

1. If you have not already entered the dispensing options menus, do steps 1 and 2 in **Selecting Dispensing Options** on page 8.
2. Press the Auto/Reset button repeatedly until **AUTO** blinks and the auto preset amount in memory is displayed to indicate that you are in the Auto Preset Amount menu. This is the amount that is displayed when the Auto/Reset button is pressed during normal operation.
3. With **AUTO** blinking and the stored auto preset amount displayed, as shown below, do **ONE** of the following two options:
 - Enter a new auto preset amount by pressing the 10 button to change the 10s digit, the 1.0 button to change the 1s digit, and the 0.1 button to change the first decimal digit.

In the figure below, the arrows point from the numbered buttons on the keypad to the corresponding digits in the display.

NOTE: If you press and hold the 10, 1.0, or 0.1 buttons, the digits advance rapidly.

To store the displayed auto preset amount in memory and advance to the Shut-Off Default Amount menu, press the Auto/Reset button.

OR

- Press the Auto/Reset button.

The currently displayed auto preset amount is retained, and the display advances to the Shut-Off Default Amount menu.

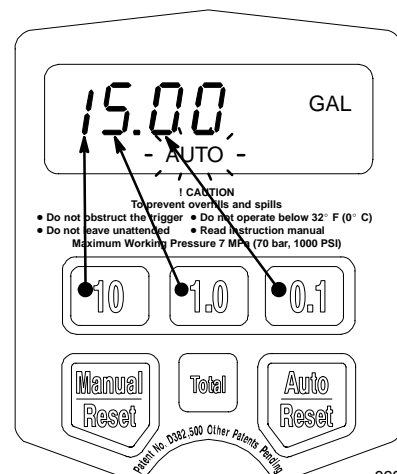

06044A

Setup

Shut-Off Default Amount

The shut-off default amount is for preventing accidental overfills when dispensing with the trigger locked in Manual mode. The shut-off default amount is factory preset at 5 quarts.

In this menu, you can change the shut-off default amount.

1. If you have not already entered the dispensing options menus, do steps 1 and 2 in **Selecting Dispensing Options** on page 8.
2. Press the Auto/Reset button repeatedly until the clock icon blinks, and the stored shut-off default amount is displayed to indicate that you are in the Shut-off Default Amount menu.

3. With the clock icon blinking and the stored shut-off default amount displayed, as shown below, do **ONE** of the following two options:

- Enter a new shut-off default amount by pressing the 10 button to change the 10s digit, the 1.0 button to change the 1s digit, and the 0.1 button the change the first decimal digit. You cannot enter zero. To lock in the new shut-off default amount and exit the dispensing options menus, press the Auto/Reset button.

The PM5 beeps and returns to the Manual dispense mode to indicate that you have exited the dispensing options menus.

OR

- Press the Auto/Reset button.

The PM5 beeps and returns to the Manual dispense mode to indicate that you have exited the dispensing options menus.

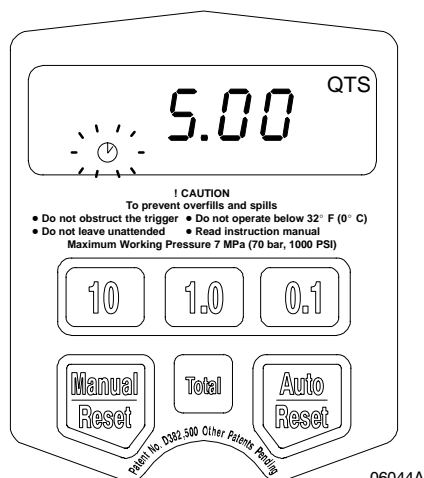

06044A

Operation

Locking and Unlocking the Trigger

The trigger on this dispense valve has a locking mechanism. In Auto mode, the unit stops dispensing when the entered amount has been dispensed. In Manual mode, the trigger does not automatically unlock; you must unlock it manually.

To lock the trigger, press on the part of the trigger that has the textured grip (see below) until you feel it click into the locked position.

To unlock the trigger, press on the smooth part of the trigger (see below) until you feel it click out of the locked position. When you release the trigger, fluid flow stops.

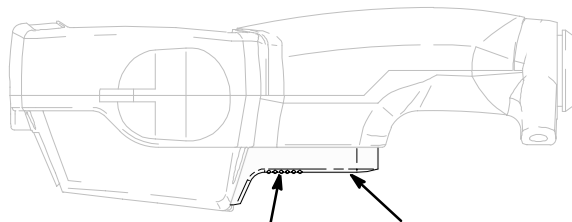

Press here
to lock.

Press here
to unlock.

06227A

Checking Segments in the Display

When you press the Manual/Reset button or the Auto/Reset button when the display is awake and in the Manual or Auto dispense mode, the Segment Check is displayed briefly. This display allows you to check for burned out segments in the display. Press the Manual/Reset or Auto/Reset button repeatedly to get a good look at each segment in the display. The Segment Check should show all of the segments shown below.

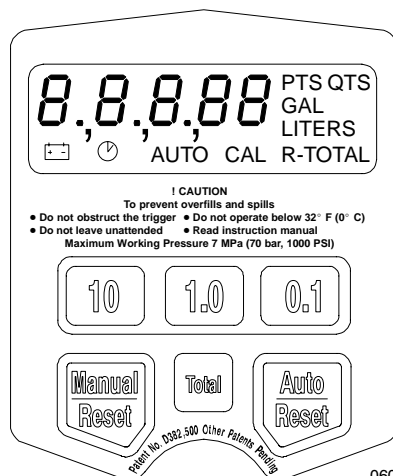

8,8,8,8 PTS QTS
GAL LITERS
AUTO CAL R-TOTAL

! CAUTION

To prevent overfills and spills

- Do not obstruct the trigger
 - Do not operate below 32° F (0° C)
 - Do not leave unattended
 - Read instruction manual
- Maximum Working Pressure 7 MPa (70 bar, 1000 PSI)

10

1.0

0.1

Manual
Reset

Total

Auto
Reset

Patent No. 6382,500 Other Patents Pending

06044A

Dispensing Fluid in Manual Mode

1. Press the Manual/Reset button.

If the display was asleep, it wakes up and displays the amount that was displayed before it fell asleep.

If the display was awake, and the meter is in the Manual dispense mode, the meter beeps, and the display clears to **0.00**.

If the display was awake, and the unit is in the Viewing Totals mode or the Auto dispense mode, the meter switches to the Manual dispense mode.

2. When the display is awake, you can dispense from zero or from the displayed amount by doing **one** of the following:

- Press the Manual/Reset button again to clear the display to **0.00** if it is not already at **0.00**. Then go to step 3.

OR

- Go straight to step 3 to dispense from the displayed amount.

3. Squeeze the trigger. You may lock it. See **Locking and Unlocking the Trigger** at left.

Fluid flows, and the amount displayed counts up from zero or the previously dispensed amount.

4. Release/unlock the trigger when you have dispensed the desired amount of fluid.

Fluid flow stops, and the amount you have dispensed is displayed.

You may press the Manual/Reset button again to reset the displayed amount to zero.

NOTE: When the trigger is released, the automatic nozzle prevents the fluid in the extension from running out.

Operation

Dispensing Fluid in Auto Mode

CAUTION

Before you begin a preset dispense cycle, make sure **AUTO** is displayed. If you do not see **AUTO** on the display, you are not in the Auto dispense mode, and fluid flow will not stop when the auto preset amount is dispensed.

1. Press the Auto/Reset button.

The display wakes up if it was asleep, and **AUTO** and the stored preset dispense amount are displayed. The factory default is **0.00**.

NOTE: To change the **stored** preset dispense amount, see **Auto Preset Amount** on page 9.

2. You can dispense or change the displayed preset amount by doing **one** of the following:
 - Go straight to step 3 to dispense the displayed preset amount.
- OR**
- To change the displayed preset amount, you can set the display to zero by pressing the Auto/Reset button, then press the 10 button to change the 10s digit, press the 1.0 button to change the 1s digit, and press the 0.1 button to change the first decimal digit. Then go to step 3.

3. Lock the trigger. See **Locking and Unlocking the Trigger** on page 11.

Fluid flows, and the displayed dispensed amount counts up from zero. When the preset amount is dispensed, the unit beeps, the trigger unlocks, fluid flow stops, the dispensed amount is displayed, and the meter switches to the Manual dispense mode.

If you want to stop fluid flow **before** the preset amount is dispensed, manually unlock the trigger. To continue the dispense, lock the trigger, and the dispensed amount resumes counting toward the preset amount.

If you want to continue dispensing **after** the trigger unlocks at the preset dispense amount, squeeze the trigger, and the dispensed amount resumes counting in the Manual dispense mode until you release the trigger.

NOTE: When the trigger unlocks, the automatic nozzle prevents the fluid in the extension from running out.

Viewing Totals

This is the procedure for viewing the non-resettable and resettable totals. To change the resettable total, see **Resettable Total** on page 8.

1. If the display is blank, press the Manual/Reset or Auto/Reset button to wake it up.
2. Press the Total button to view the non-resettable total amount.

If the unit of measurement is gallons, quarts, or pints, the total is displayed in gallons, as shown below. If the unit of measurement is liters, the total is displayed in liters.

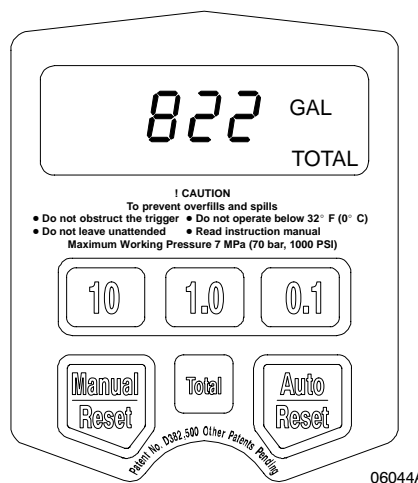

3. Press the Total button again to view the resettable total amount.

If the unit of measurement is gallons, quarts, or pints, the resettable total is displayed in gallons, as shown below. If the unit of measurement is liters, the resettable total is displayed in liters.

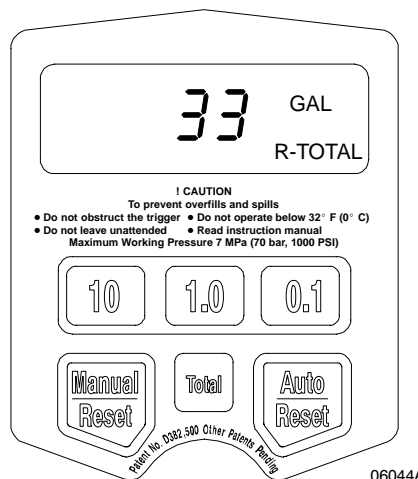

Pressing the Total button repeatedly toggles between the non-resettable and resettable total.

4. Press the Manual/Reset or Auto/Reset button to return to the Manual or Auto dispensing mode.

Troubleshooting

Relieve the pressure before you check or repair the meter. Be sure all other valves and controls and the pump are operating properly.

WARNING

To reduce the risk of serious injury whenever you are instructed to relieve pressure, always follow the **Pressure Relief Procedure** on page 5.

Problem	Cause	Solution
Battery icon is displayed.	Battery is low.	Replace the battery. See Replacing the Battery on page 16.
Battery icon is blinking, and bAtt is blinking.	Battery is dead.	Replace the battery. See Replacing the Battery on page 16.
Display does not activate.	Battery is defective or dead. Electronic control is malfunctioning. A dispense mode has not been selected.	Replace the battery. See Replacing the Battery on page 16. Replace the entire unit. Select a dispense mode by pressing the Manual/Reset button or the Auto/Reset button.
Slow or no fluid flow	Filter is clogged. Pump pressure is low. Shut-off valve is not fully open. Foreign material is jammed in the meter housing.	1. Relieve the pressure. 2. Clean or replace the filter. See Replacing the Filter on page 16. 3. If the problem remains, contact your Graco distributor for repair or replacement. Turn up pump pressure. Fully open shut-off valve. Contact your Graco distributor for repair or replacement.
Displayed dispensed amount is not accurate.	Unit needs to be calibrated for the fluid that is being dispensed.	Calibrate the meter for the fluid that is being dispensed. See Calibration Factor on page 9.

continued

Troubleshooting

Problem	Cause	Solution
<p>Meter leaks from: Cover/Control</p>	<p>Poor swivel (3)/hose connection.</p> <p>Poor swivel (3)/meter housing connection.</p> <p>Damaged valve stem (16) assembly.</p> <p>Poor seal at meter housing plate.</p> <p>NOTE: Place a straight edge along meter housing plate. If flat, plate and seal are ok. If plate is not flat, meter is damaged.</p>	<p>Apply Teflon® tape (leave minimum 2 engaged threads uncovered for electrical continuity) or sealant to threads of hose and tighten the connection. See step 9 in Installation Procedure.</p> <p>Torque the fitting to 20–25 ft.lb.</p> <p>Replace or clean valve stem and O-rings. See Servicing the Valve.</p> <p>Contact your Graco distributor for repairs or replacement.</p>
<p>Meter leaks from: Automatic nozzle</p> <p>NOTE: It is important to distinguish between the two causes of this problem. A new nozzle will not correct a fluid leak caused by a faulty valve.</p>	<p>Automatic nozzle (5b, 6b, or 7b) has a damaged seal.</p> <p>Valve (16) has damaged or obstructed seals.</p>	<p>Replace the nozzle. See Replacing the Automatic Nozzle on page 17.</p> <p>Replace or clean valve stem and o-rings. See Servicing the Valve on page 17.</p>
<p>Meter leaks from: Swivel</p>	<p>Poor swivel (3)/hose connection</p> <p>Poor swivel (3)/meter housing connection.</p>	<p>Apply Teflon® tape (leave minimum 2 engaged threads uncovered for electrical continuity) or sealant to threads of hose and tighten the connection. See step 9 in Installation Procedure.</p> <p>Torque the fitting to 20–25 ft.lb.</p>
<p>Unit does not stop dispensing when assumed auto amount is dispensed.</p>	<p>Auto amount was not entered.</p> <p>Trigger is obstructed, or unit has been set down resting on its trigger.</p>	<p>Enter a preset dispense amount in the Auto dispense mode. AUTO must be displayed below the amount.</p> <p>Never set the unit down resting on its trigger.</p>

Troubleshooting

Error Codes

Error codes are listed below. Even in an error condition, the unit keeps track of the amount dispensed. With any error code displayed, as shown at right, you can

- Press the Manual/Reset button.
Error code is cleared, unit switches into Manual mode, and dispensed amount is displayed.
- Press the Auto/Reset button.
Error code is cleared, unit switches into Auto mode, and the preset amount is displayed.

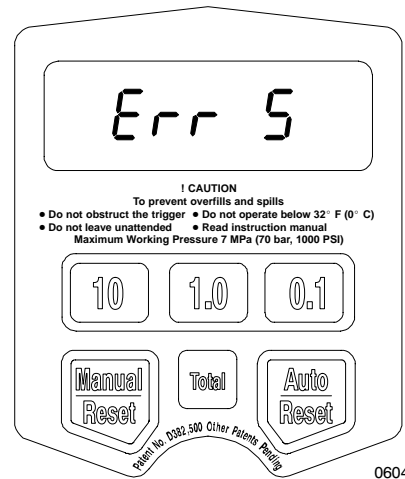

06044A

Error Code	Cause	Solution
Err 2	<p>Switch Error: Error occurred with pick-up in internal gear, or flow range is too high.</p> <p>Air was pumped through the line.</p> <p>Unit was dropped or encountered excessive vibration during shipping.</p>	<p>Ensure that your flow rate is not higher than 5 gpm. For further assistance, contact your Graco distributor.</p> <p>Purge air from the line.</p> <p>Press the Manual/Reset button at start-up.</p>
Err 4	<p>Flow has continued after it should have shut off.</p>	<p>Check if the unit is resting on the trigger or if an obstruction is pressing the trigger. <i>The unit checks for flow every two seconds, and it beeps and repeats the error code until the trigger is released and the error code cleared.</i></p>
Err 5	<p>The unit has dispensed the shut-off default amount and has stopped fluid flow.</p>	<p>Press the Manual/Reset button, and dispense again. To change the shut-off default amount, see the Shut-off Default Amount section on page 10.</p>
Err 6	<p>A preset dispense amount of zero was entered for the dispense or is stored as the default, and a Preset dispense was attempted.</p>	<p>Enter an amount that is not zero. See the Auto Preset Amount section on page 9.</p>

Service

Replacing the Battery

! WARNING



FIRE AND EXPLOSION HAZARD

Only replace the battery in a non-hazardous location, away from flammable fluids or fumes.

You may order battery Part No. 113716 separately.

Battery required to meet safety approvals:
Duracell MN1604, PC1604

or
Eveready EN22, 522

! CAUTION

Before you replace the battery, press the Manual/Reset button, which clears the dispensed amount to zero. This saves everything to memory.

The low-battery and dead-battery displays are explained in the **Troubleshooting** chart on page 13.

To change the battery, press the Manual/Reset button, remove the impact guard (28), remove the battery cover (2), and put in a new battery.

Replacing the Filter

The filter (25) is replaceable. To replace the filter, do the following:

1. Relieve the pressure.

! WARNING

To reduce the risk of serious injury whenever you are instructed to relieve pressure, always follow the **Pressure Relief Procedure** on page 5.

2. Unscrew the hose from the swivel (3).
3. Remove the o-ring (27), and remove the old filter (25) from its seat in the swivel (3) with an o-ring pick.
4. Push the new filter (25) into the swivel (3), and make sure it is properly seated. Replace the o-ring (27).

NOTE: Orient the new filter (25) so the concave side of the screen points downstream, as shown below.

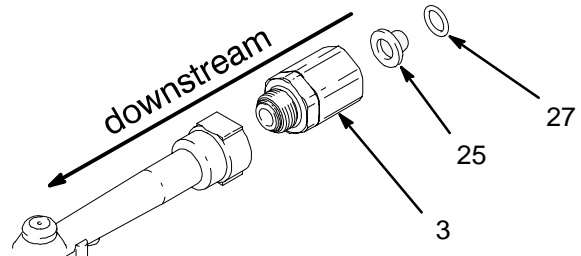

5. Screw the hose back into the swivel (3).

Service

Servicing the Valve

Valve Repair Kit 240453 is available and can be ordered separately. See the **Parts List** on page 18 and the **Parts Drawing** on page 19. The parts with asterisks next to their reference numbers are available in the Valve Repair Kit.

When you are repairing the valve with new parts from the Valve Repair Kit, use **all** of the new parts. To replace the parts, do the following:

1. **Relieve the pressure.**

⚠ WARNING

To reduce the risk of serious injury whenever you are instructed to relieve pressure, always follow the **Pressure Relief Procedure** on page 5.

2. Remove the six screws (21) that hold the cover (1) together, and open the cover.
 3. Remove the trigger (15) from the valve stem (16b*).
 4. Unscrew the valve seat (16e*), remove the valve seat and valve stem assembly (16b*) from the meter housing, and pull the valve stem assembly out of the valve seat.
 5. Discard the old valve stem assembly (16b*) and the spring (16a*).
 6. Apply lubricant to all new parts. Place the new spring (16a*) in the new valve stem assembly (16b*), push the new valve stem assembly back into the valve seat (16e*), place the valve stem assembly, seat and spring into the meter housing, thread the valve seat into the meter housing, and torque to 140 to 150 in-lb (16 to 17 N.m).
- NOTE:** Take care that the spring (16a*) does not get pinched when you install the valve stem assembly (16) into the meter housing.
7. Place the trigger (15) on the valve stem assembly (16b*), put the cover (1) together, thread in the six screws that hold the cover together, and torque to 7 to 10 in-lb (0.8 to 1.1 N.m).

Replacing the Automatic Nozzle

The automatic nozzle (5b, 6b, or 7b) is not serviceable. If it leaks, replace it as follows:

1. **Relieve the pressure.**

⚠ WARNING

To reduce the risk of serious injury whenever you are instructed to relieve pressure, always follow the **Pressure Relief Procedure** on page 5.

2. Remove the old nozzle from the extension with an open-end adjustable wrench on the flats of the nozzle bushing. See below.

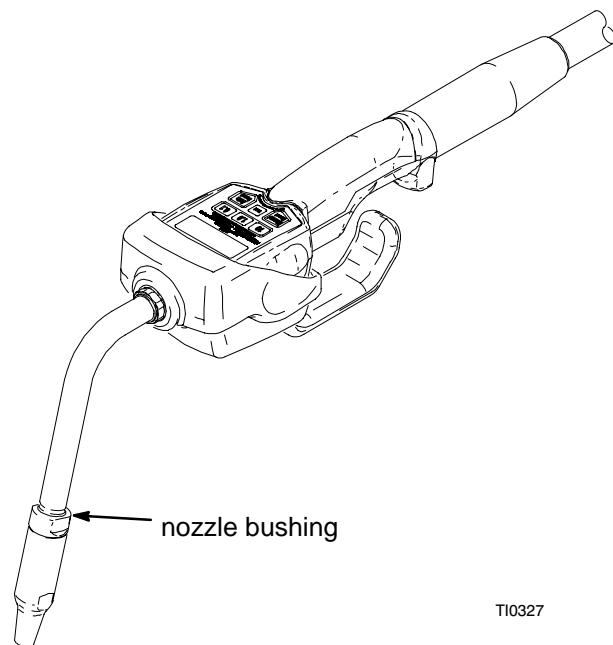

T10327

3. Thread the new nozzle (5b, 6b, or 7b) onto the extension, and tighten it firmly with an open-end adjustable wrench.

NOTE: **Only** tighten the nozzle with the wrench on the flats of the nozzle bushing. Do not disassemble the bushing from the nozzle. Disassembly will affect the performance of the nozzle.

⚠ WARNING

Do not use the old Graco nozzle (Part No. 203655) or any other manual shut-off nozzle on the PM5 extension. You must use the new automatic nozzle that is provided with the PM5, or the meter could be damaged. Do not use any sealant material.

Parts List

Ref. No.	Part No.	Description	Qty.	Ref. No.	Part No.	Description	Qty.
1	238551	COVER/CONTROL	1	8	113716	BATTERY; standard 9V, alkaline	1
2	191351	COVER, battery	1	15	191046	TRIGGER	1
3	240416	SWIVEL, straight	1	16	240453	KIT, valve repair <i>(includes 16a to 16e, 25, and 27)</i>	
4	191286	SWIVEL COVER, black		16a*		SPRING, compression	1
	191287	SWIVEL COVER, red		16b*		VALVE STEM ASSEMBLY	1
	191288	SWIVEL COVER, blue		16c*		O-RING, packing	1
	191289	SWIVEL COVER, green		16d*		O-RING, packing	1
	191290	SWIVEL COVER, yellow	1	16e*		SEAT, valve	1
5	239949	NOZZLE ASSEMBLY <i>For Models 238501 & 238503 (includes 5a through 5c)</i>		21	113412	SCREW, pan-head; 6-19x3/4	6
5a	191036	.TUBE; 75° bend	1	24▲	290205	LABEL, warning	1
5b	239829	.NOZZLE, automatic	1	25*	114017	FILTER	1
5c	113419	.NUT, seal; 3/8 in.-18 NPT	1	27*	109018	O-RING	1
6	239951	NOZZLE ASSEMBLY <i>For Models 238502 & 238504 (includes 6a through 6b)</i>		28	243758	GUARD, impact	1
6a	238370	.HOSE, flexible; 3/8 in. coupled	1	* <i>These parts are included in Valve Repair Kit 240453, which can be ordered separately.</i>			
6b	239829	.NOZZLE, automatic	1	▲ <i>Extra Warning labels are available for free.</i>			
6c	113419	.NUT, seal; 3/8 in.-18 NPT	1				
6d	155699	.ELBOW, street	1				
7	239950	NOZZLE ASSEMBLY <i>For Models 238505 & 238506 (includes 7a through 7d)</i>					
7a	191038	.TUBE, 15° bend; 3/8 in.	1				
7b	239829	.NOZZLE, automatic	1				
7c	113419	.NUT, seal; 3/8 in.-18 NPT	2				
7d	155699	.ELBOW, street	1				

Parts Drawing

1 Torque to 7 to 10 in-lb (0.8 to 1.1 N.m).

2 Torque to 140 to 150 in-lb (16 to 17 N.m).

3 Apply lubricant when reassembling.

4 Torque to 20 to 25 ft-lb (27 to 34 N.m).

* These parts are included in Valve Repair Kit 240453, which can be ordered separately.

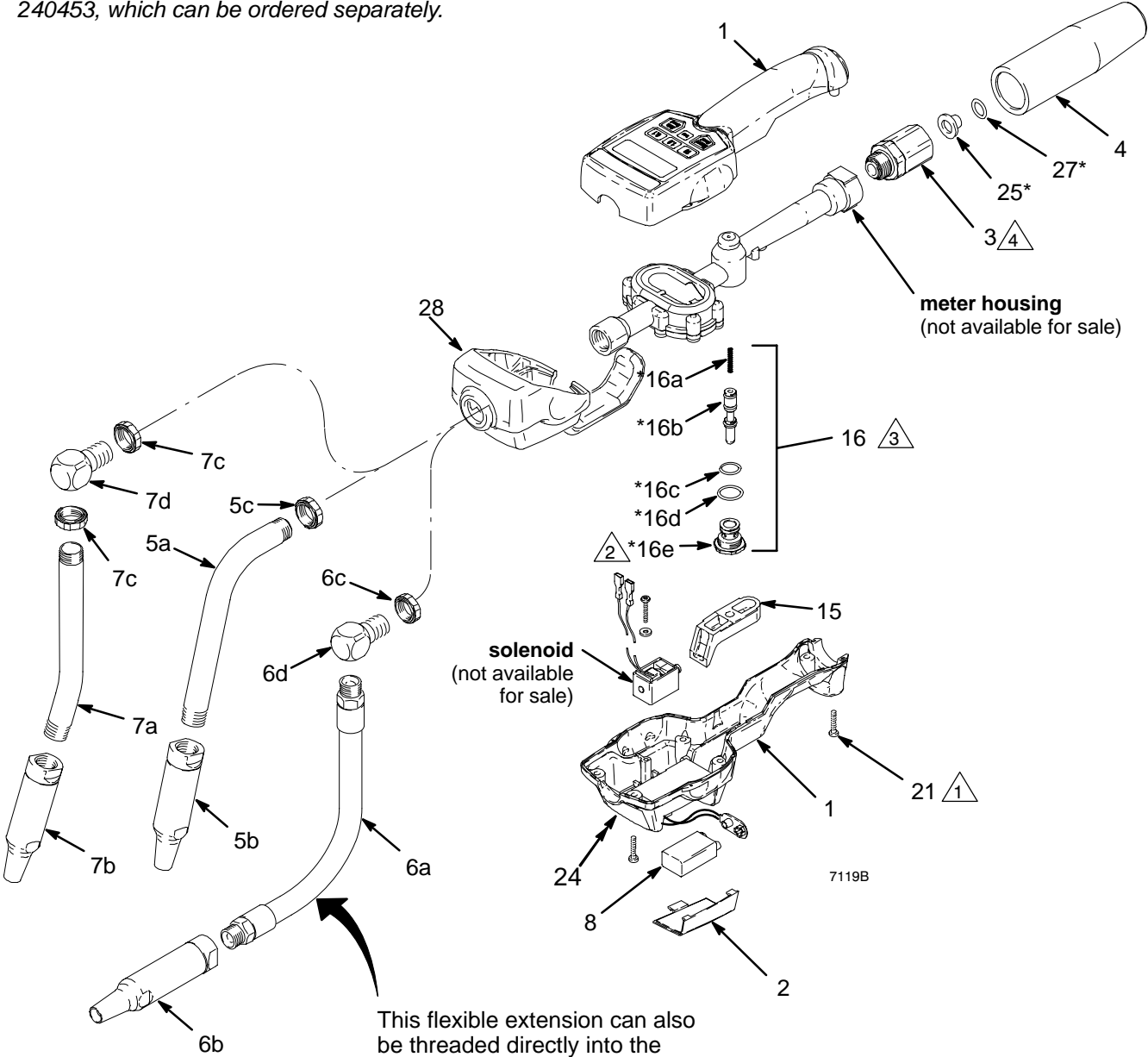

This flexible extension can also be threaded directly into the meter outlet without the street elbow (6d) or sealing nut (6c).

Technical Data

Flow range*	0.26 to 5 gpm (1 to 18.9 lpm)
Operating pressure range	45 to 1000 psi (0.29 to 7 MPa, 2.9 to 69 bar)
Weight	3 lb (1.36 kg)
Units of measurement	factory-set in quarts or liters maximum totalizer amount = 99999 gallons or liters maximum recorded dispensed volume = 999.99 units maximum preset volume = 99.9 units
Inlet	1/2 npt
Outlet	3/8 npt
Operating temperature range	32° F to 120° F (0° C to 49° C)
Storage temperature range	-30° F to 120° F (-34° C to 49° C)
Battery**	standard 9 volt
Expected battery life in typical shop environment	6 months
Wetted parts	zinc, stainless steel #304, Zenite®, carbon steel, polyurethane, nitrile rubber
Fluid compatibility	lubricating oils, antifreeze mixtures
Meter valve assembly pressure loss at 1.5 gpm (5.7 lpm) with 30-weight oil at 70° F (21° C)	17 psi (117 kPa, 1.2 bar)
Accuracy†	+/- 0.5 percent
Repeatability‡	+/- 0.15 percent

* Tested in No. 10 motor oil. Flow rates vary with fluid pressure and viscosity.

** Battery required to meet safety approvals: Duracell® MN1604 or Eveready® EN22, 522

† At 2.5 gpm (9.5 lpm), at 70° F (21° C), with 10-weight oil, and 1 gallon dispensed. May require calibration; out-of-box accuracy is +/- 1.25 percent.

‡ At 2.5 gpm (9.5 lpm), at 70° F (21° C), with 10-weight oil, and 1 gallon dispensed.

Teflon® and Zenite® are registered trademarks of the DuPont Company.

Duracell® is a registered trademark of Duracell Inc.

Panasonic® is a registered trademark of Panasonic Industrial Co.

Dimensional Drawing

- A 14.0 in. (356 mm) outlet to end of swivel cover
- B 3.75 in. (95 mm) widest cross section (including impact guard)
- C 3.10 in. (79 mm) keypad to bottom of impact guard

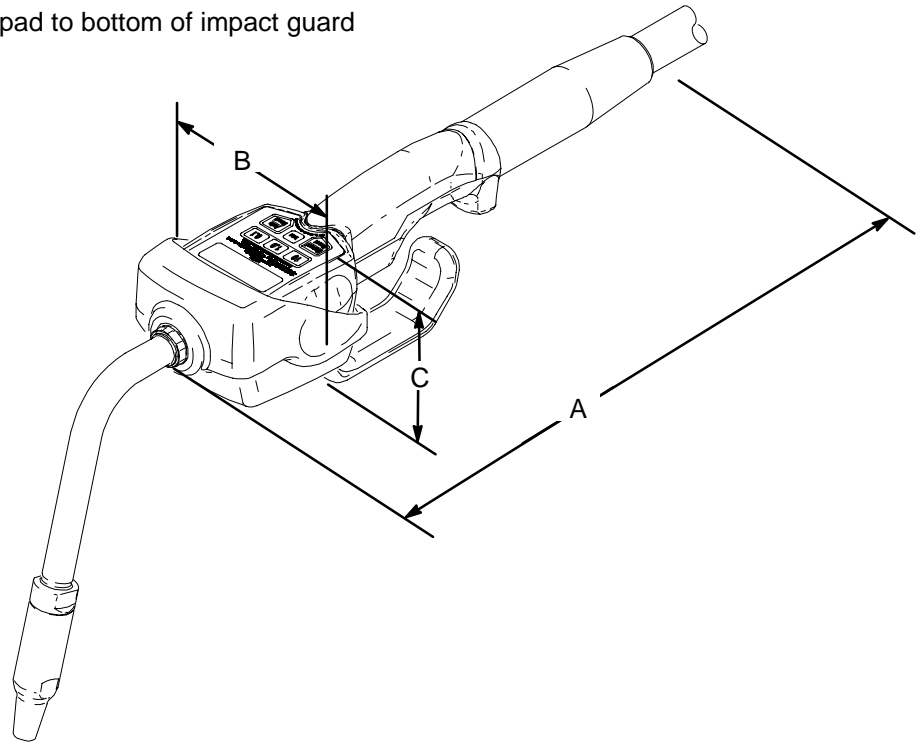

T10327

Graco Standard Warranty

Graco warrants all equipment manufactured by Graco and bearing its name to be free from defects in material and workmanship on the date of sale by an authorized Graco distributor to the original purchaser for use. With the exception of any special, extended, or limited warranty published by Graco, Graco will, for a period of two (2) years from the date of sale, repair or replace any part of the equipment determined by Graco to be defective, including defects in the electronic meter control, which will be repaired or replaced for two (2) years from the date of sale. This warranty applies only when the equipment is installed, operated and maintained in accordance with Graco's written recommendations.

This warranty does not cover, and Graco shall not be liable for general wear and tear, or any malfunction, damage or wear caused by faulty installation, misapplication, abrasion, corrosion, inadequate or improper maintenance, negligence, accident, tampering, or substitution of non-Graco component parts. Nor shall Graco be liable for malfunction, damage or wear caused by the incompatibility of Graco equipment with structures, accessories, equipment or materials not supplied by Graco, or the improper design, manufacture, installation, operation or maintenance of structures, accessories, equipment or materials not supplied by Graco.

This warranty is conditioned upon the prepaid return of the equipment claimed to be defective to an authorized Graco distributor for verification of the claimed defect. If the claimed defect is verified, Graco will repair or replace free of charge any defective parts. The equipment will be returned to the original purchaser transportation prepaid. If inspection of the equipment does not disclose any defect in material or workmanship, repairs will be made at a reasonable charge, which charges may include the costs of parts, labor, and transportation.

THIS WARRANTY IS EXCLUSIVE, AND IS IN LIEU OF ANY OTHER WARRANTIES, EXPRESS OR IMPLIED, INCLUDING BUT NOT LIMITED TO WARRANTY OF MERCHANTABILITY OR WARRANTY OF FITNESS FOR A PARTICULAR PURPOSE.

Graco's sole obligation and buyer's sole remedy for any breach of warranty shall be as set forth above. The buyer agrees that no other remedy (including, but not limited to, incidental or consequential damages for lost profits, lost sales, injury to person or property, or any other incidental or consequential loss) shall be available. Any action for breach of warranty must be brought within three (3) years of the date of sale.

Graco makes no warranty, and disclaims all implied warranties of merchantability and fitness for a particular purpose in connection with accessories, equipment, materials or components sold but not manufactured by Graco. These items sold, but not manufactured by Graco (such as electric motors, switches, hose, etc.), are subject to the warranty, if any, of their manufacturer. Graco will provide purchaser with reasonable assistance in making any claim for breach of these warranties.

In no event will Graco be liable for indirect, incidental, special or consequential damages resulting from Graco supplying equipment hereunder, or the furnishing, performance, or use of any products or other goods sold hereto, whether due to a breach of contract, breach of warranty, the negligence of Graco, or otherwise.

FOR GRACO CANADA CUSTOMERS

The parties acknowledge that they have required that the present document, as well as all documents, notices and legal proceedings entered into, given or instituted pursuant hereto or relating directly or indirectly hereto, be drawn up in English. Les parties reconnaissent avoir convenu que la rédaction du présente document sera en Anglais, ainsi que tous documents, avis et procédures judiciaires exécutés, donnés ou intentés à la suite de ou en rapport, directement ou indirectement, avec les procédures concernées.

Graco Phone Number

TO PLACE AN ORDER, contact your Graco distributor, or call this number to identify the distributor closest to you:
1-800-533-9655 Toll Free

*All written and visual data contained in this document reflects the latest product information available at the time of publication.
Graco reserves the right to make changes at any time without notice.*

Sales Offices: Minneapolis, Detroit
International Offices: Belgium, Korea, Hong Kong, Japan

GRACO INC. P.O. BOX 1441 MINNEAPOLIS, MN 55440-1441

www.graco.com

PRINTED IN USA 308735 February 1998, Revised July 2000