

OPW 200TG AST MECHANICAL TANK GAUGE

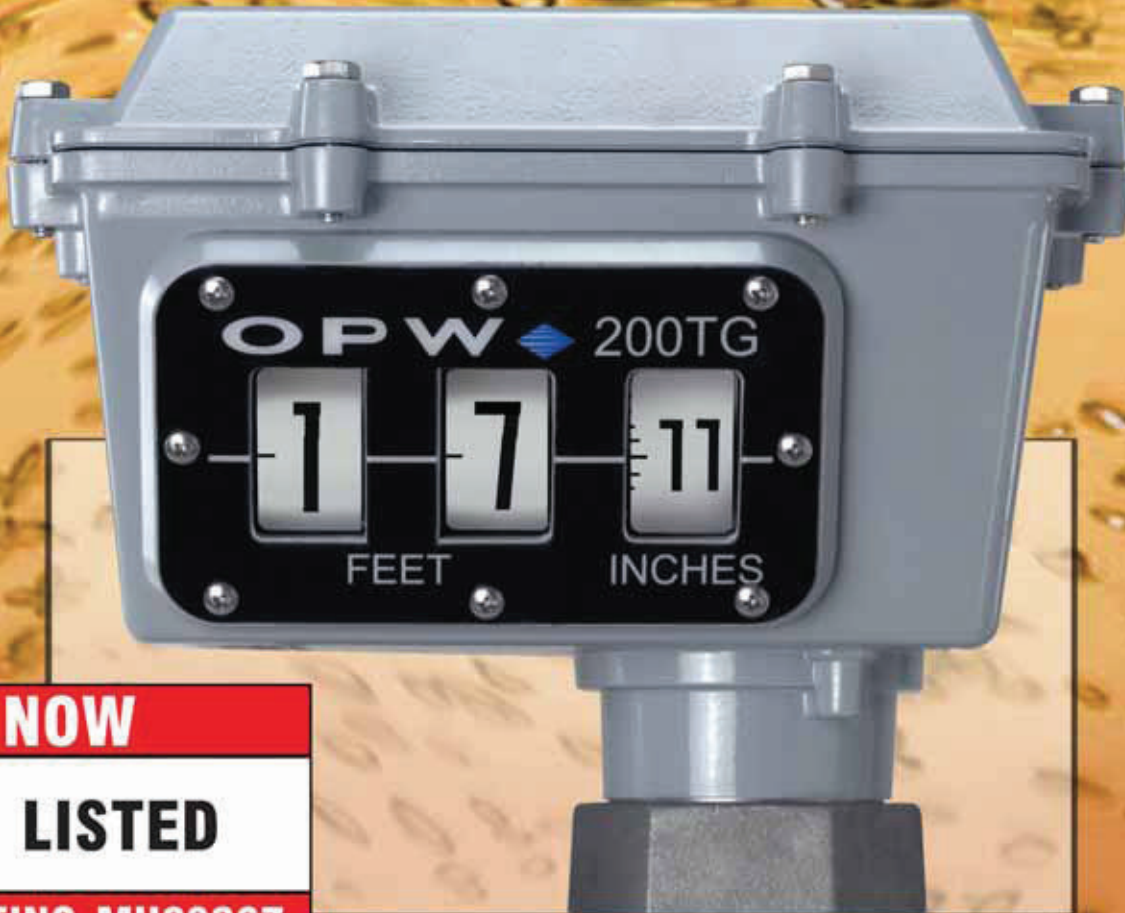

NOW



LISTED

UL LISTING MH29367

OPW 

A **DOVER** COMPANY

Materials

- Enclosure:** powder-coated aluminum
- Swivel Base:** hard-coat aluminum
- Float:** 304 stainless steel
- Lenses:** tempered borosilicate
- Gears:** acetal
- Gaskets & O-Rings:** Nitrile®
- All Hardware:** stainless steel



OPW 200TG AST MECHANICAL TANK GAUGE

The OPW 200TG Tank Gauge is designed for reading liquid levels in horizontal or vertical aboveground storage tanks. The 200TG Tank Gauge provides an accurate numerical counter readout, eliminating the need for any on-site manual gauging.

Features

- ◆ **Vapor-Tight** – Allows for standard tank pressure testing and sealing up to 25-psig (1.72 bar).
- ◆ **Angled Face** – Improves visibility from ground on large diameter tanks. May be read easily up to 30 feet away (9.14 m).
- ◆ **Swivel Adaptor Base** – Allows for 360 degrees of rotation of gauge face for easy viewing wherever needed.
- ◆ **Easy Installation** – 2" NPT-threaded base reduces labor time, and comes standard with female thread. A "H11421RS" may be purchased for male threaded applications.
- ◆ **Corrosion-Resistant Construction** – A powder-coated die cast-aluminum body assures for long service life in many fluids.
- ◆ **Drop Tube** – Prevents float entanglement in the tank, and gives the gauge a more accurate reading when turbulence is present (Drop Tubes sold separately. They are recommended for use in tanks with high turbulence, and where other piping and structures inside the tank may cause entanglement).
- ◆ **Float Buoyancy** – Designed to float in all approved fuels with a specific gravity of 0.65 and greater.
- ◆ **Tank Height** – Unit designed for use on any horizontal or vertical aboveground tank up to 18 feet (5.5 m) in depth. Specials available upon request.
- ◆ **Numbering** – Black letters on white background for ultimate contrast and better visibility. Characters stand over 1" (25 mm) tall.
- ◆ **Unit Measurement** – Can be purchased in metric units to read in meters, 1/10, 1/100, or in English units to read in feet and inches.
- ◆ **Maintenance** – No annual maintenance required.
- ◆ **U.S. Patent No.:** 6,523,404 - Other Patents Pending.
- ◆ **Compatible Fuels**– See chart on page 168.
- ◆ **Temperature Rating** – 120°F to -40°F (49°C to -40°C)

200TG Tank Gauge Instruction Sheet Order Number: **H14912PA**

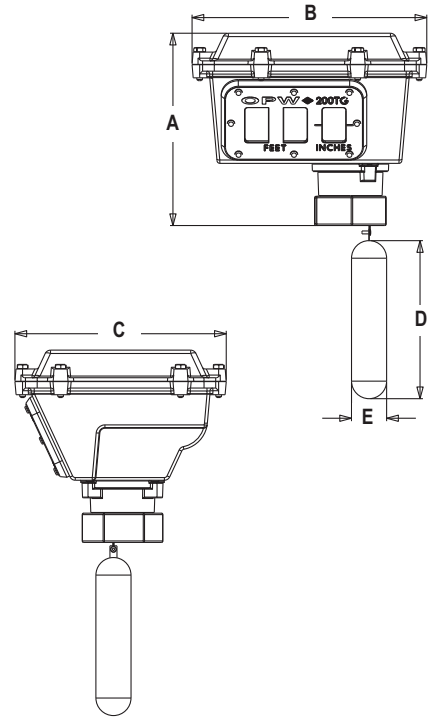

Dimensions:

	in.	cm
A	8 1/4	21
B	10 1/4	26
C	9	22.75
D	6 3/4	17.25
E	1 1/2	3.75

Replacement Parts:

Part #	Description
C05165M	Float
H14358M	Lens
H14909M	Lid Gasket

Ordering Specifications:

Product #	Description	lb.	kg
200TG-ENG	English Unit Tank Gauge up to 18 ft.	7.75	3.52
200TG-ENG40	English Unit Tank Gauge - 40 ft.	7.75	3.52
200TG-MET	Metric Unit Tank Gauge up to 6 m	7.75	3.52
200TG-MET40	Metric Unit Tank Gauge - 10 m	7.75	3.52

(Ancillary Equipment)

Product #	Description	lb.	kg
H11421RS	2" NPT Male x Male Nipple	1.5	0.68
61T-0208	2" Dia. x 8' Long Drop Tube	2.67	1.21
61T-0212	2" Dia. x 12' Long Drop Tube	4.00	1.81
61T-0216	2" Dia. x 16' Long Drop Tube	5.33	2.42

Listings and Certifications



Underwriters Laboratory Listed UL Listing MH29367. Liquid level gauges which are intended to be used on above ground storage tanks and monitor the level of petroleum-based flammable or combustible fluids.